

# HYDMARK APPLICON

## FILTRATION TROLLEY

MODELS HF 05 & HF 10



### APPLICATIONS

- Filtration & transfer of new fluid from storage tank to reservoir.
- Periodic filtration of fluid already being used.
- For fluids having viscosity up to 800 cst, diesel, hydraulic oil, lubricating oil etc.
- Separation of water from a system.

### FEATURES

- Compact unit with rugged & durable heavy duty frame.
- Portable, easy to handle & light weight.
- Long inlet & outlet hoses - so no additional tools required for operation.
- With motor starter, 5 meter Cable, it is ready to use as received.
- Different filtration Capacity cartridges available.
- Separate inlet & outlet filters for pump protection & long life of element.
- Flow by pass system & motor overload protection in case of emergency.
- Easy to replace filter elements.
- Indicators to check clogging of filters.

### ADVANTAGES

- Saves time spent on filling & transfer of oil.
- Periodic use of trolley increases life of hydraulic oil.
- Improves performance of pumps, valves, cylinders etc.
- Reduces oxidations of oil & stabilizes its viscosity level.
- Consistent use of this trolley improves life of the machine & efficiency, thereby increasing the profit levels.

### MODEL CODE

HF - 0520 - 149 - 25 - 3 - WA - 9 - J001 - 0589

Motor Power	Flow Rate
0520 0.5 HP	20 lpm
1040 1 HP	40 lpm

Inlet filter  
149 micron  
74 micron

Outlet filter rating  
25 micron rating  
10 micron rating  
5 micron rating

Additional filter  
3 micron rating  
5 micron rating  
Omit otherwise

Month & year of manufacture

Job no.

Design no.

WA Water removal additional cartridge  
WO Water removal outlet cartridge  
Omit otherwise

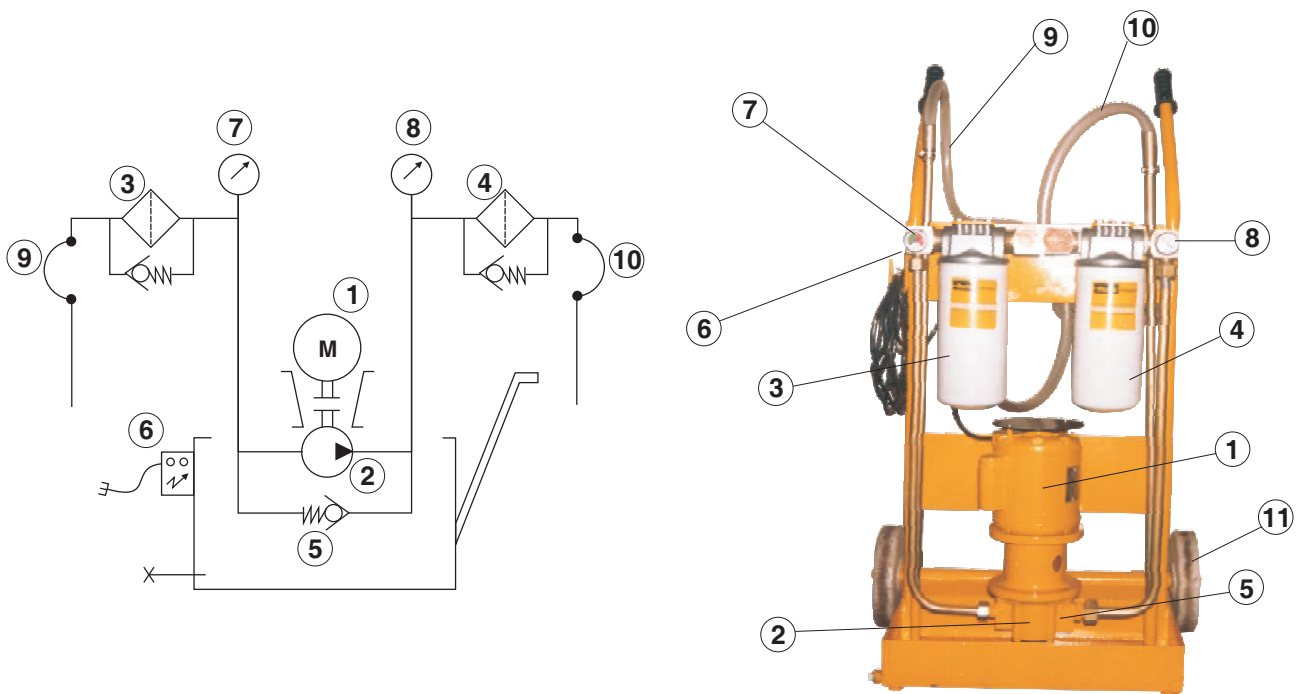
**SPECIFICATIONS, SPARES CODE & HYDRAULIC CIRCUIT**

S.NO.	PART	SPARES CODE	SPECIFICATIONS
1	ELECTRIC MOTOR	E05 / E10	0.5 HP/1 HP 1 PHASE , 1440 RPM 220 V 50Hz AC
2	GEAR PUMP	G20 / G40	20 LPM , 40 LPM
3	INTAKE FILTER	I149 / I74	74/149 MICRON ABSOLUTE FILTRATION RATING, SS MESH
4	DELIVERY FILTER / DELIVERY FILTER CARTRIDGES	D05 / D10 / D25 DE 05 / DE 10 / DE 25	5/10/25 MICRON ABSOLUTE FILTRATION RATING, PAPER MESH
5	SAFETY VALVE	C10	SET PRESSURE - 5 BAR
6	MOTOR STARTER	ES 05 / ES 10	DOL, WITH OVERLOAD PROTECTION
7	INTAKE CLOGGING INDICATOR	PI 50	2" DIAL, 1/8" BSP CONNECTION (CHANGE FILTER WHEN IT INDICATES RED).
8	DELIVERY CLOGGING INDICATOR	PD 50	2" DIAL, 1/8" BSP CONNECTION (CHANGE FILTER WHEN IT INDICATES RED).
9	DELIVERY HOSE	DH	HIGH QUALITY, NON KINKING LENGTH 2 METERS
10	SUCTION HOSE	SH	HIGH QUALITY, NON KINKING LENGTH 2 METERS
11	TROLLEY WHEELS	W8 B2	Ø 8" X 2" WIDTH - NYLON
12	WATER REMOVAL DELIVERY FILTER WATER REMOVAL DELIVERY CARTRIDGE	WD 05 / WD 10 / WD 25 WED 05 / WED 10 / WED 25	OPTIONAL OR ADDITIONAL FILTER

For special filtration applications & further information contact

**HYDMARK APPLICON**

A-5/4, PHASE II, INDUSTRIAL AREA, MAYA PURI, NEW DELHI - 110 064

PHONE : 011-45114611 (30 Lines), FAX : 011-28116246

E-mail: [sales@hydmark.com](mailto:sales@hydmark.com)